

**.danneels**

**ABML**  
ARCHITECTENBUREAU MANU LENDERS

**LOT 1 - 402 m<sup>2</sup>**

**PLANNENBUNDEL - NIEUWE TOESTAND**

schaal: 1 : 300 - maatvoering in cm  
bouwheer: - D3 Projects  
datum: 02/03/2026

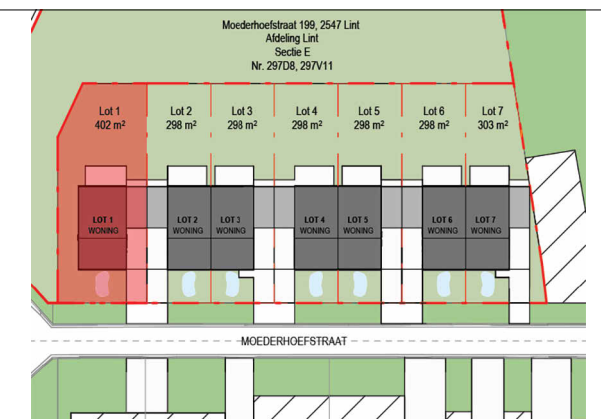
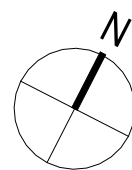

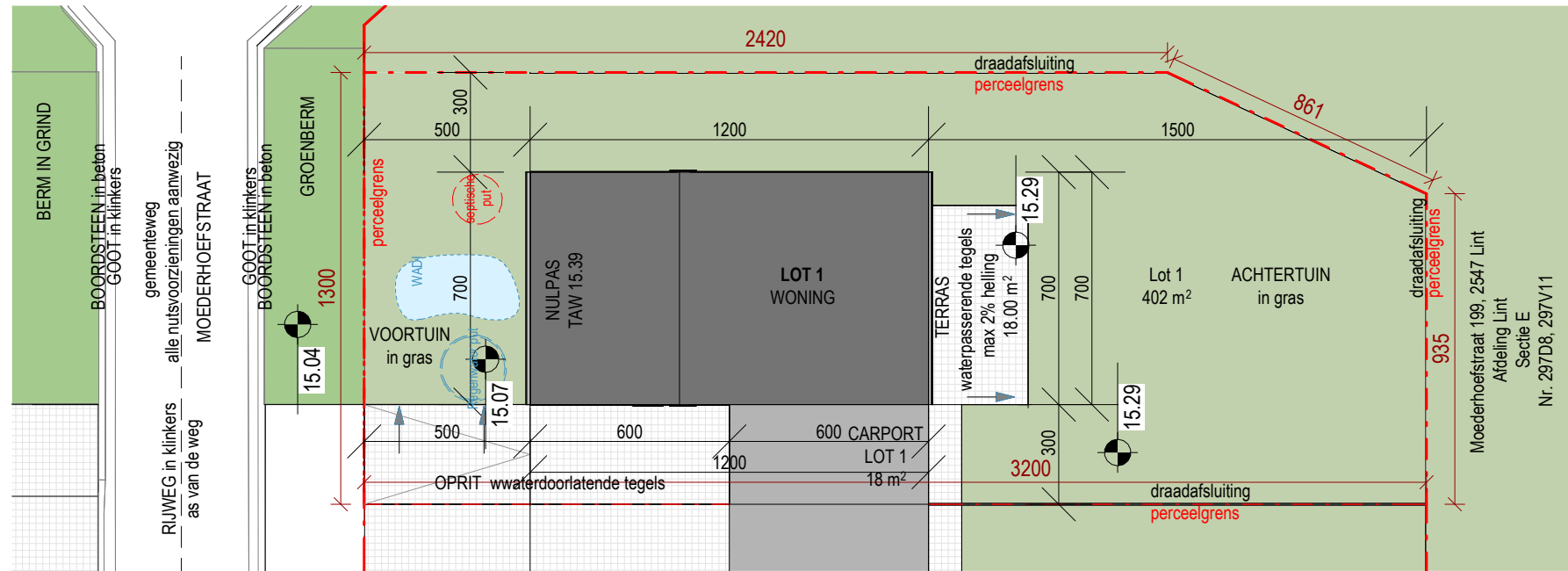

Moederhoefstraat 199, 2547 Lint  
Afdeling Lint  
Sectie E  
Nr. 297D8, 297V11

**.danneels**

**ABML**  
ARCHITECTENBUREAU MANU LENDERS

**LOT 1 - 402 m²**

**INPLANTINGSPLAN - NIEUWE TOESTAND**

schaal: 1 : 200 - maatvoering in cm  
 bouwheer: - D3 Projects  
 datum: 02/03/2026

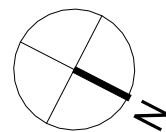

0 1 m 5 m

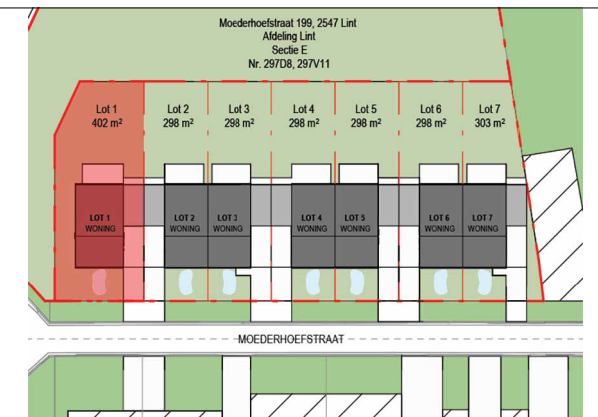

1200  
 712 14 400 37

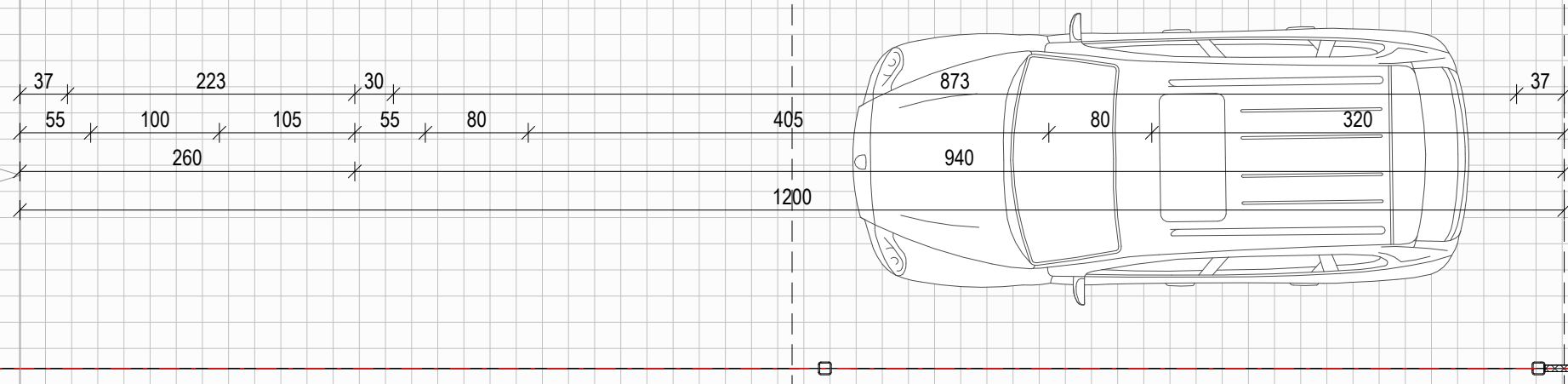
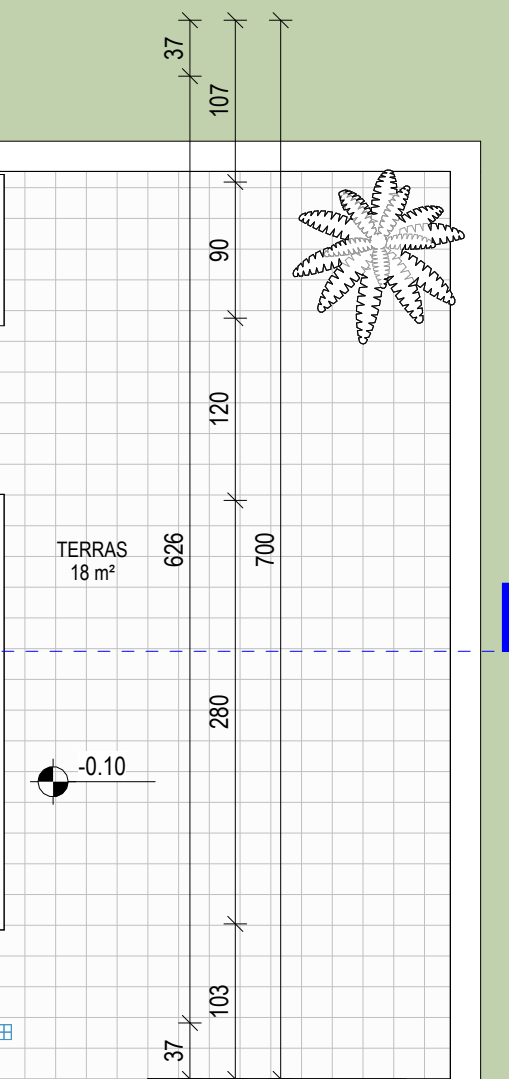
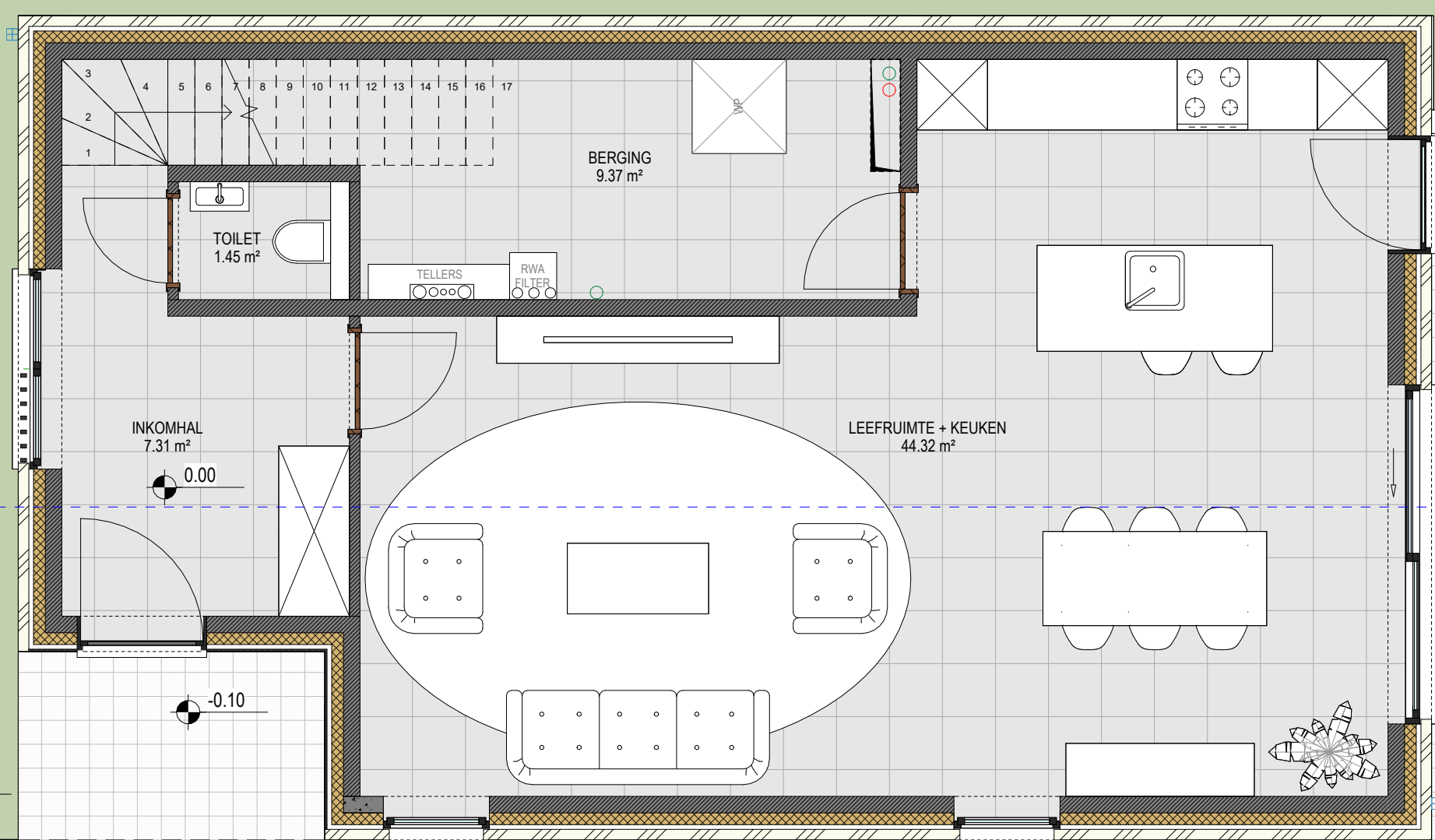
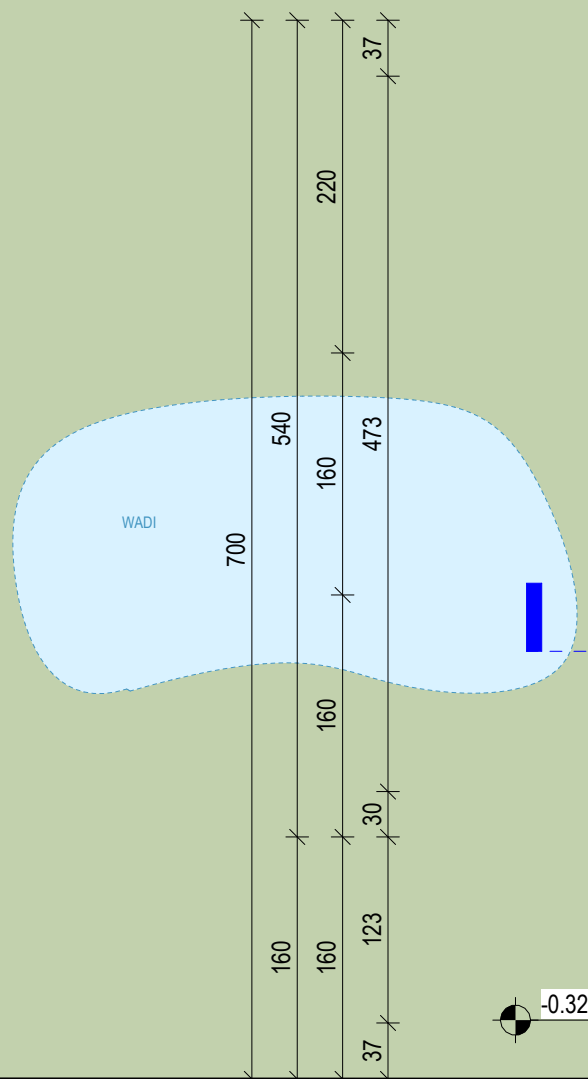

perceelgrens lot 1

**.danneels**

**ABML**  
 ARCHITECTENBUREAU MANU LENDERS

**LOT 1 - 402 m<sup>2</sup>**  
**GELIJKVLOERS - NIEUWE TOESTAND**

schaal: 1 : 50 - maatvoering in cm  
 bouwheer: - D3 Projects  
 datum: 02/03/2026

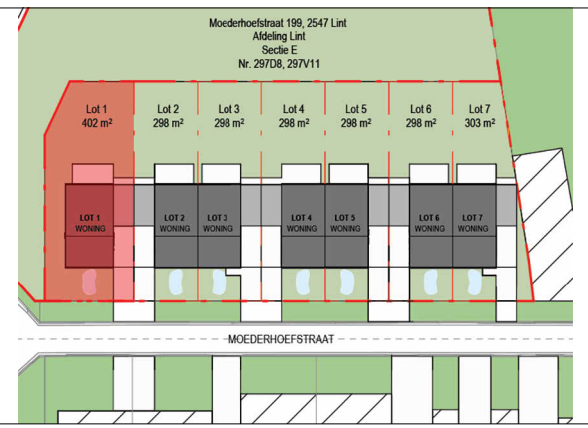
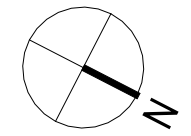

1200  
 421 80 491 69 138  
 37 479 9 225 9 287 154

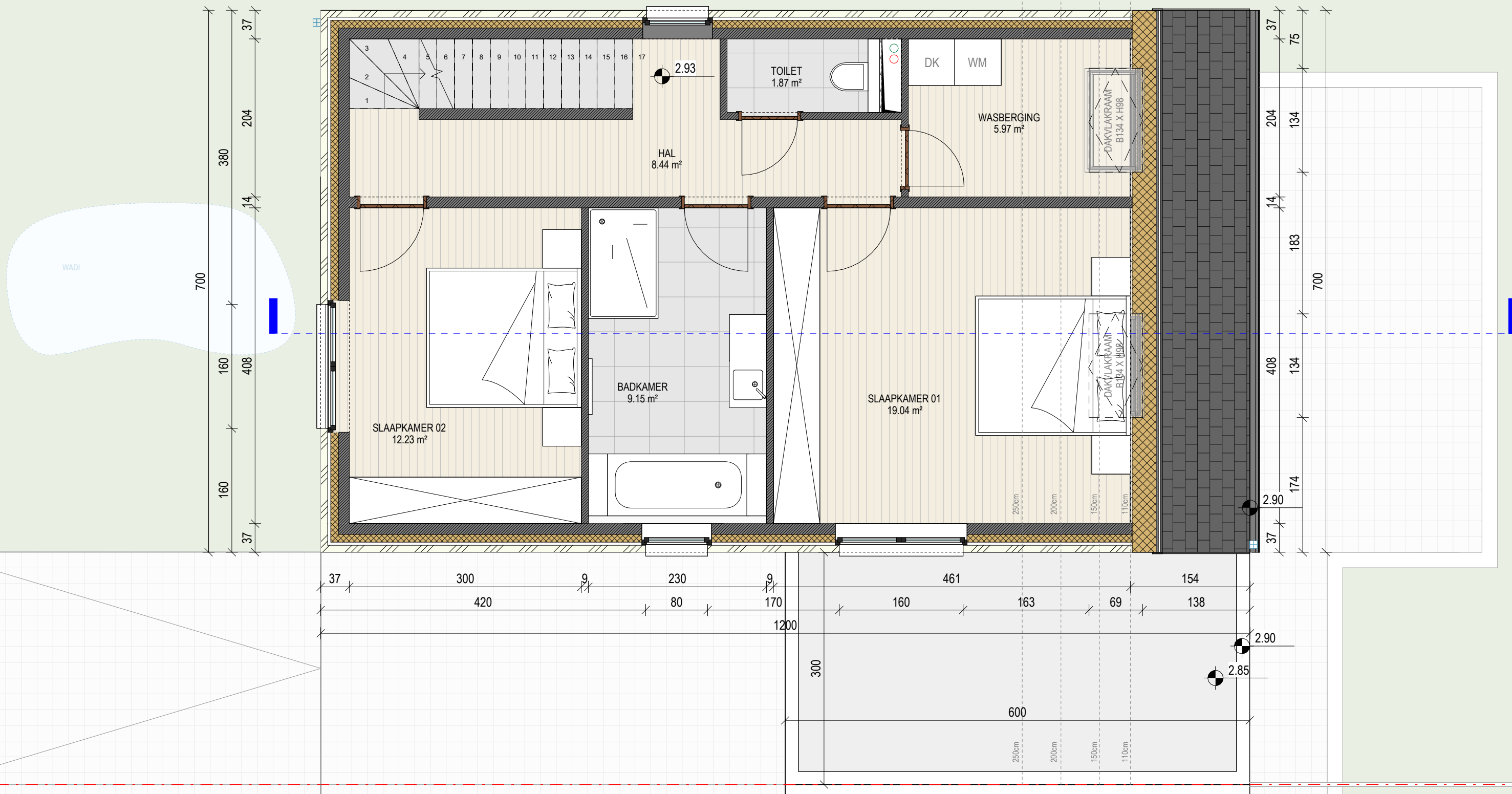

37 300 9 230 9 461 154  
 420 80 170 160 163 69 138  
 1200 300 2.90 2.85  
 600 250cm 200cm 150cm 110cm

**LOT 1 - 402 m<sup>2</sup>**  
**EERSTE VERDIEPING - NIEUWE TOESTAND**

schaal: 1 : 50 - maatvoering in cm  
 bouwheer: - D3 Projects  
 datum: 02/03/2026

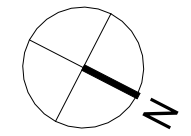

**.danneels**

**ABML**  
 ARCHITECTENBUREAU MANU LENDERS

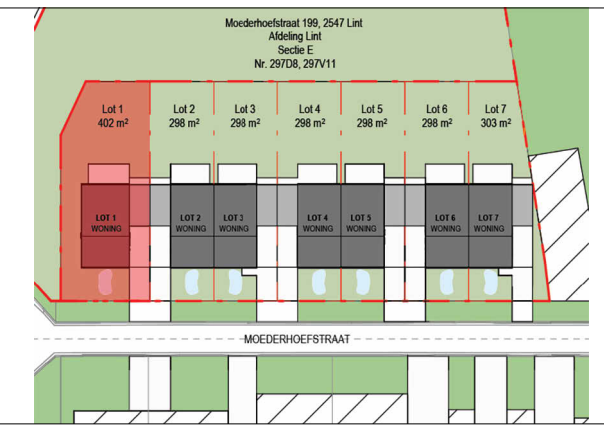

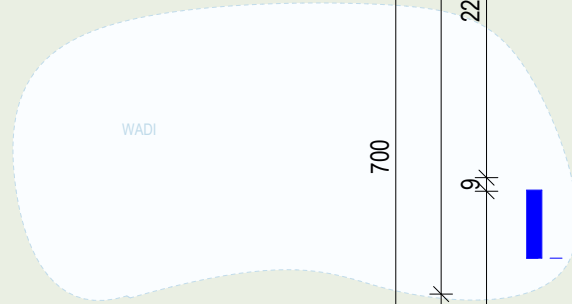
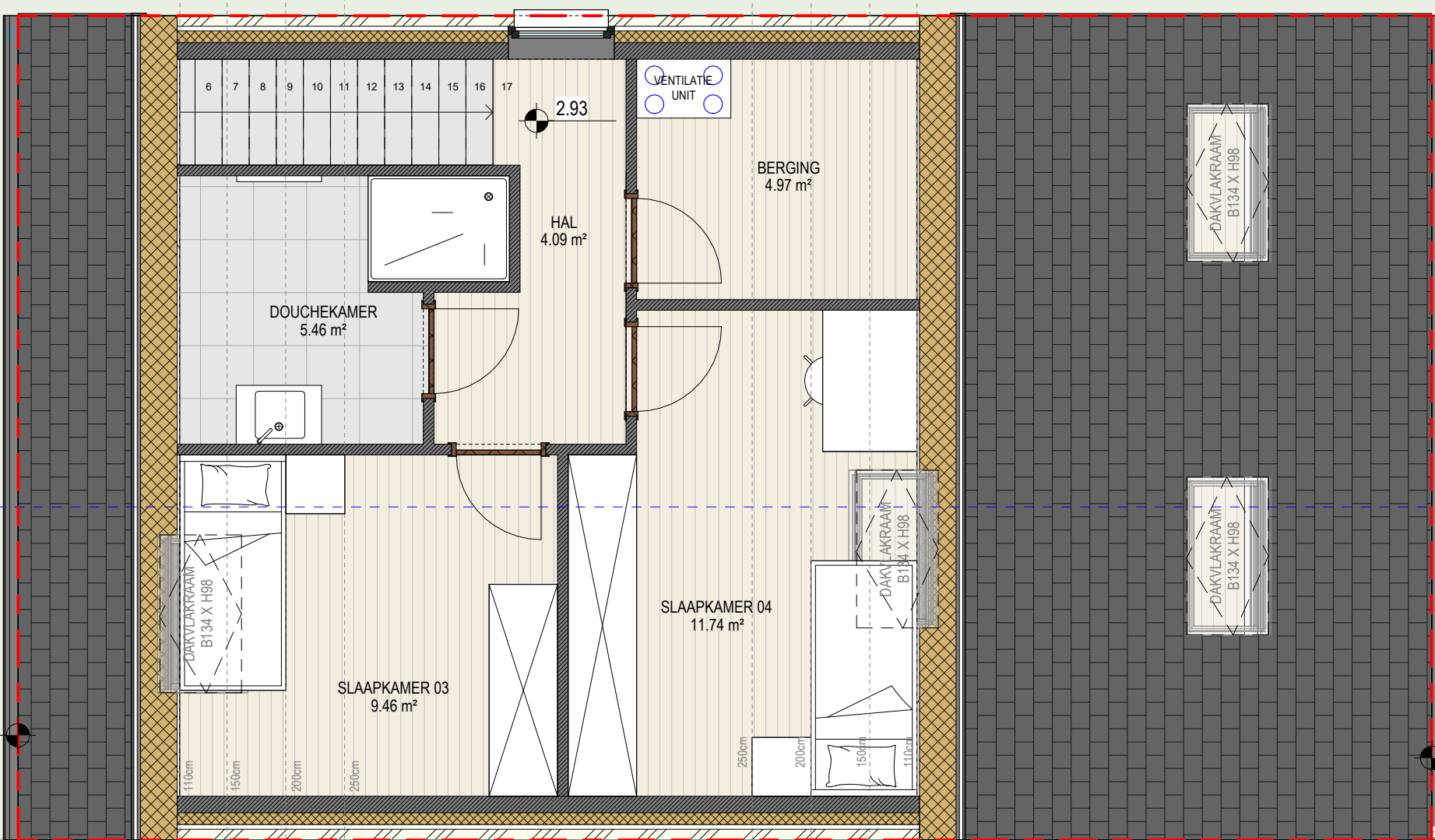
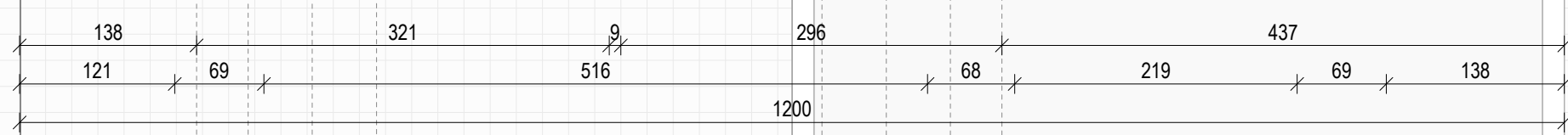
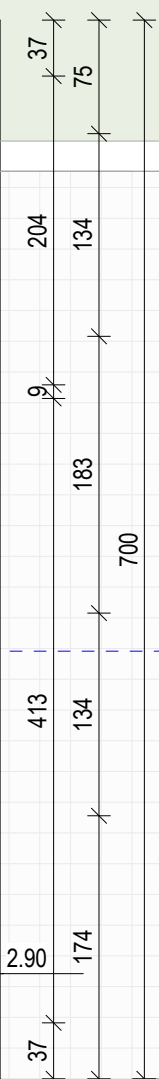
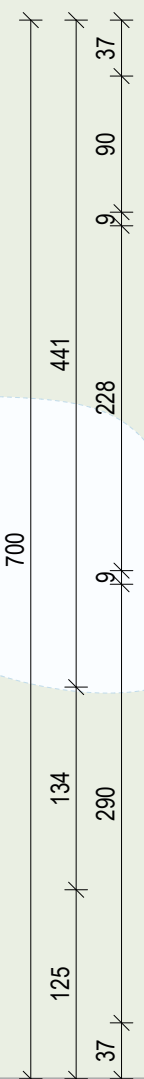
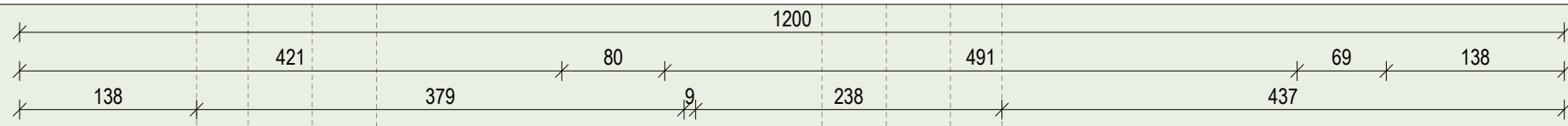

perceelgrens lot 1

**.danneels**

**ABML**  
ARCHITECTENBUREAU MANU LENDERS

**LOT 1 - 402 m<sup>2</sup>**  
**TWEEDE VERDIEPING - NIEUWE TOESTAND**

schaal: 1 : 50 - maatvoering in cm  
bouwheer: - D3 Projects  
datum: 02/03/2026

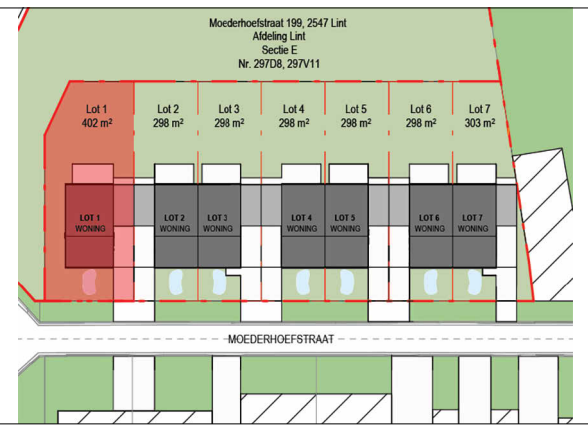
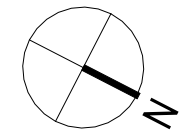



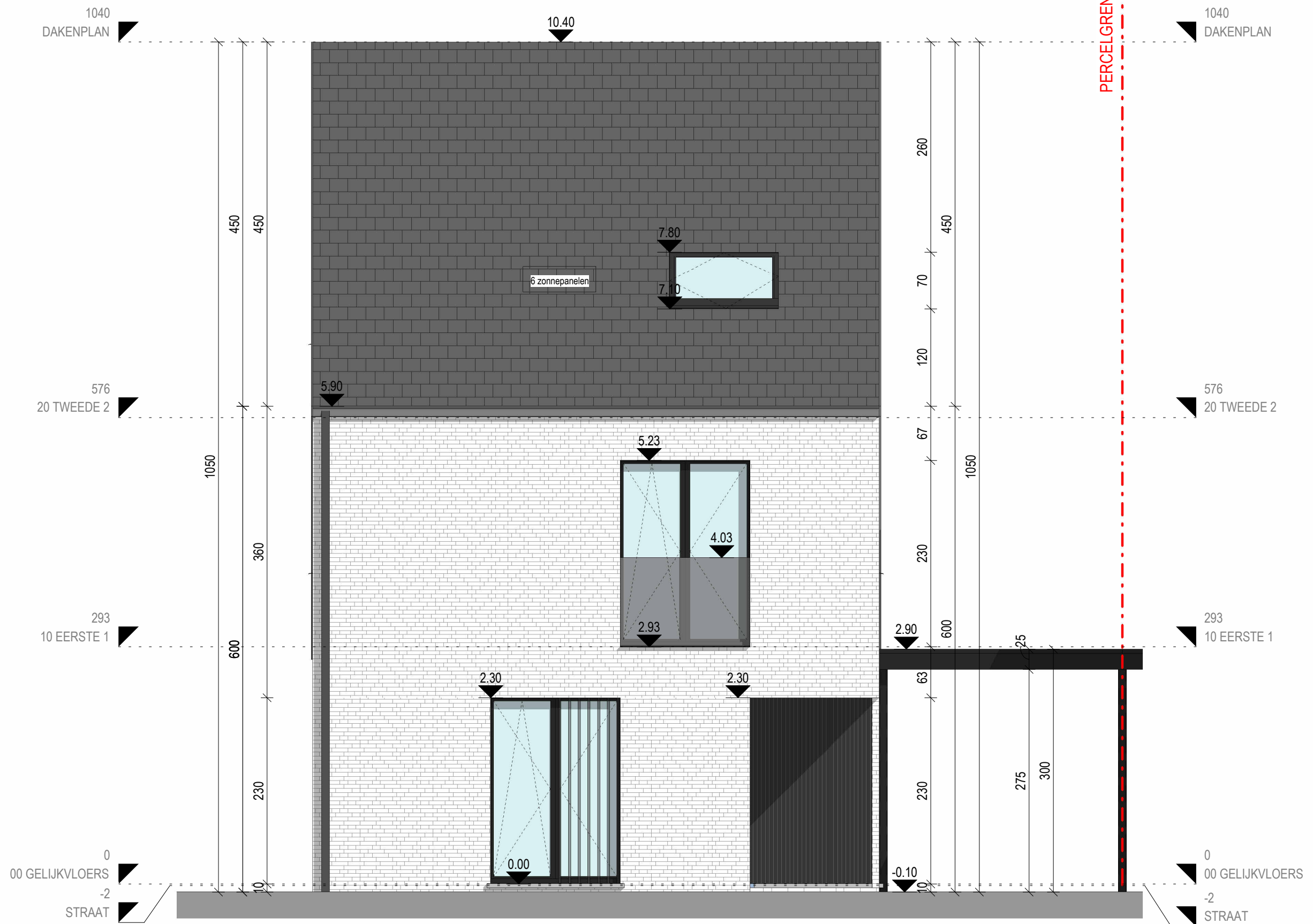

**.danneels**

**ABML**  
ARCHITECTENBUREAU MANU LENDERS

**LOT 1 - 402 m<sup>2</sup>**

**VOORGEVEL - NIEUWE TOESTAND**

schaal: 1 : 50 - maatvoering in cm  
 bouwheer: - D3 Projects  
 datum: 02/03/2026

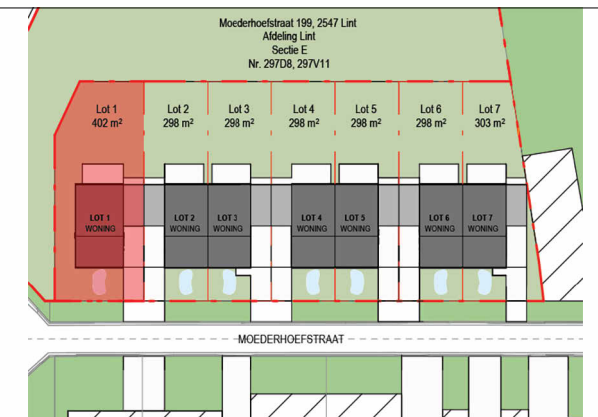

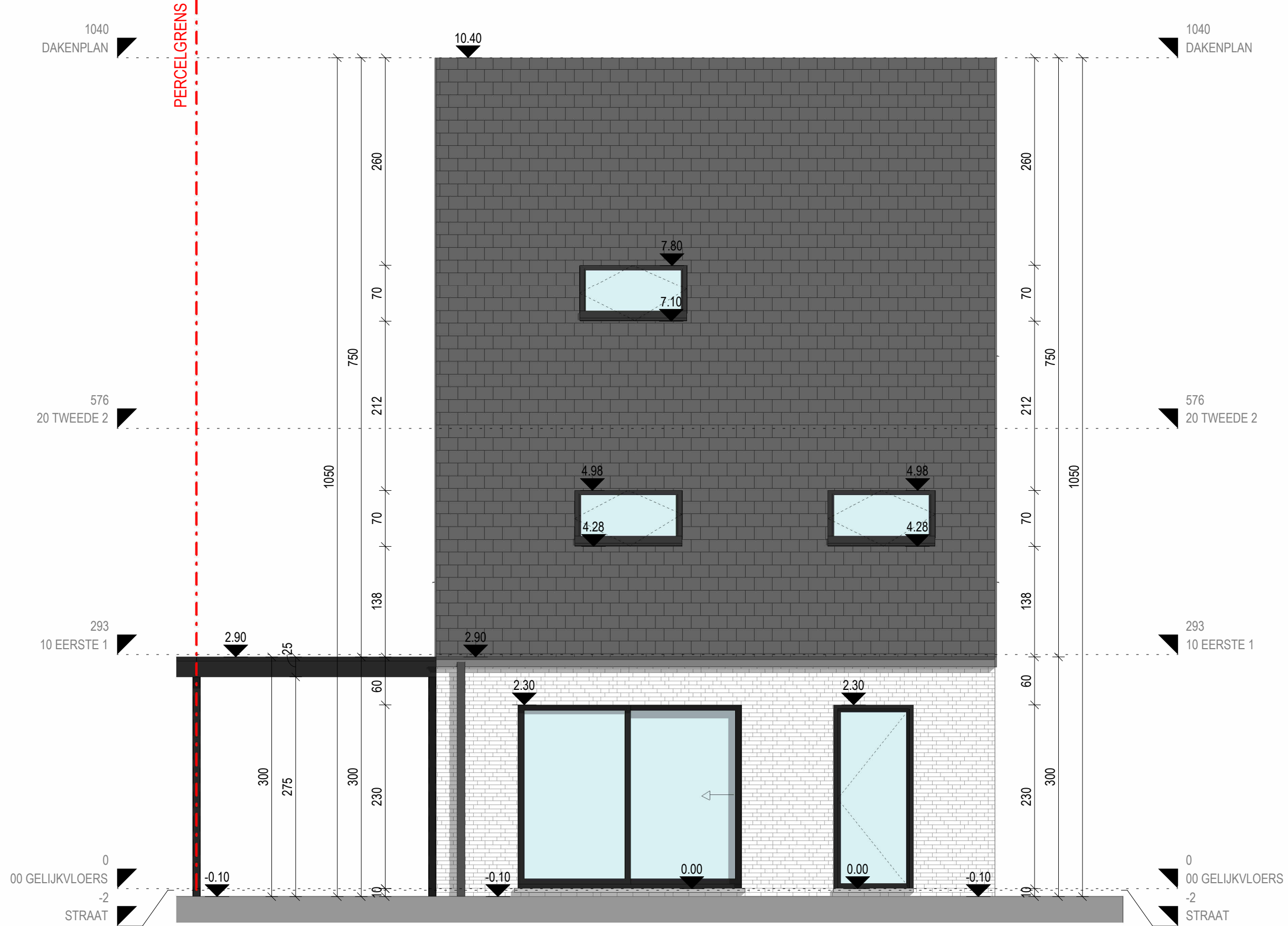

**.danneels**

**ABML**  
ARCHITECTENBUREAU MANU LENDERS

**LOT 1 - 402 m<sup>2</sup>**

**ACHTERGEVEL - NIEUWE TOESTAND**

schaal: 1 : 50 - maatvoering in cm  
 bouwheer: - D3 Projects  
 datum: 02/03/2026

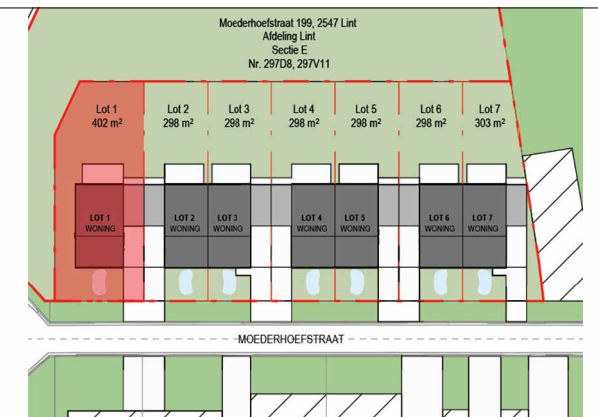

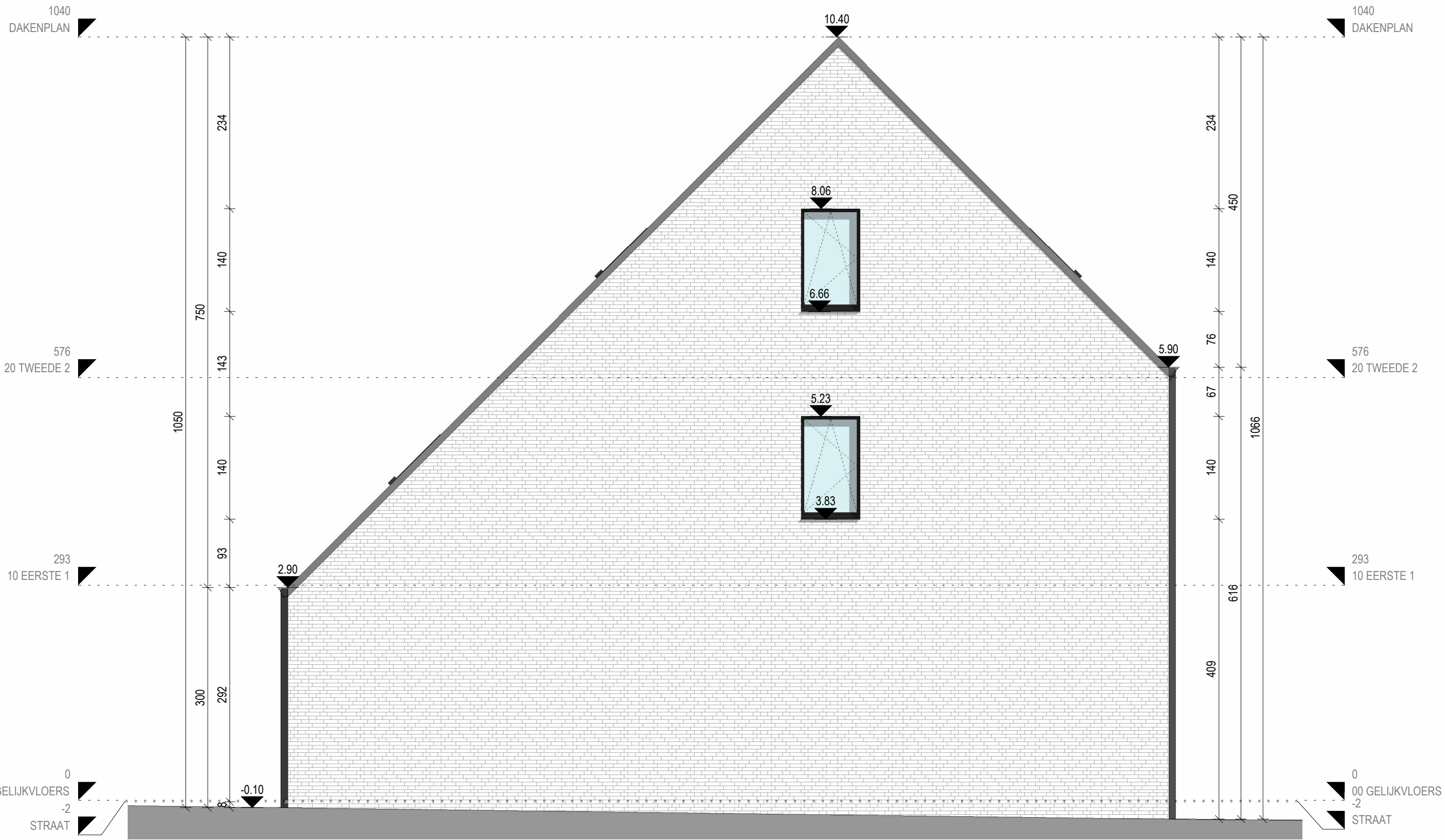

**.danneels**

**ABML**  
ARCHITECTENBUREAU MANU LENDERS

**LOT 1 - 402 m<sup>2</sup>**

**ZIJGEVEL LINKS - NIEUWE TOESTAND**

schaal: 1 : 50 - maatvoering in cm  
 bouwheer: - D3 Projects  
 datum: 02/03/2026

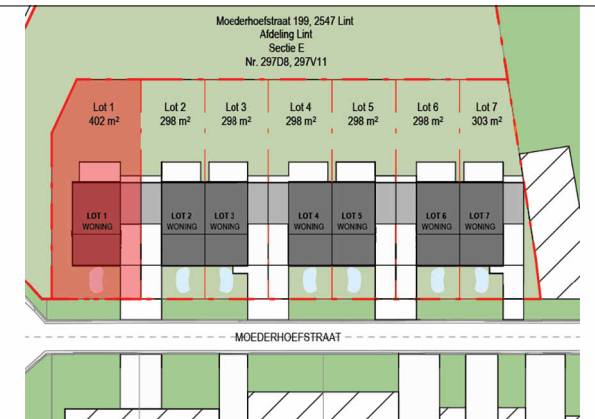



**.danneels**

**ABML**  
ARCHITECTENBUREAU MANU LENDERS

**LOT 1 - 402 m<sup>2</sup>**

**ZIJGEVEL RECHTS - NIEUWE TOESTAND**

schaal: 1 : 50 - maatvoering in cm  
 bouwheer: - D3 Projects  
 datum: 02/03/2026

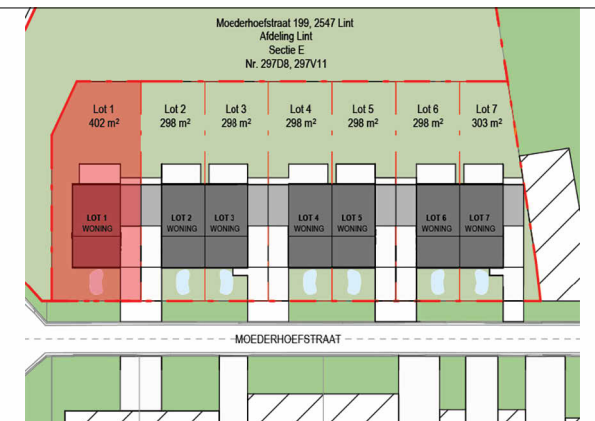

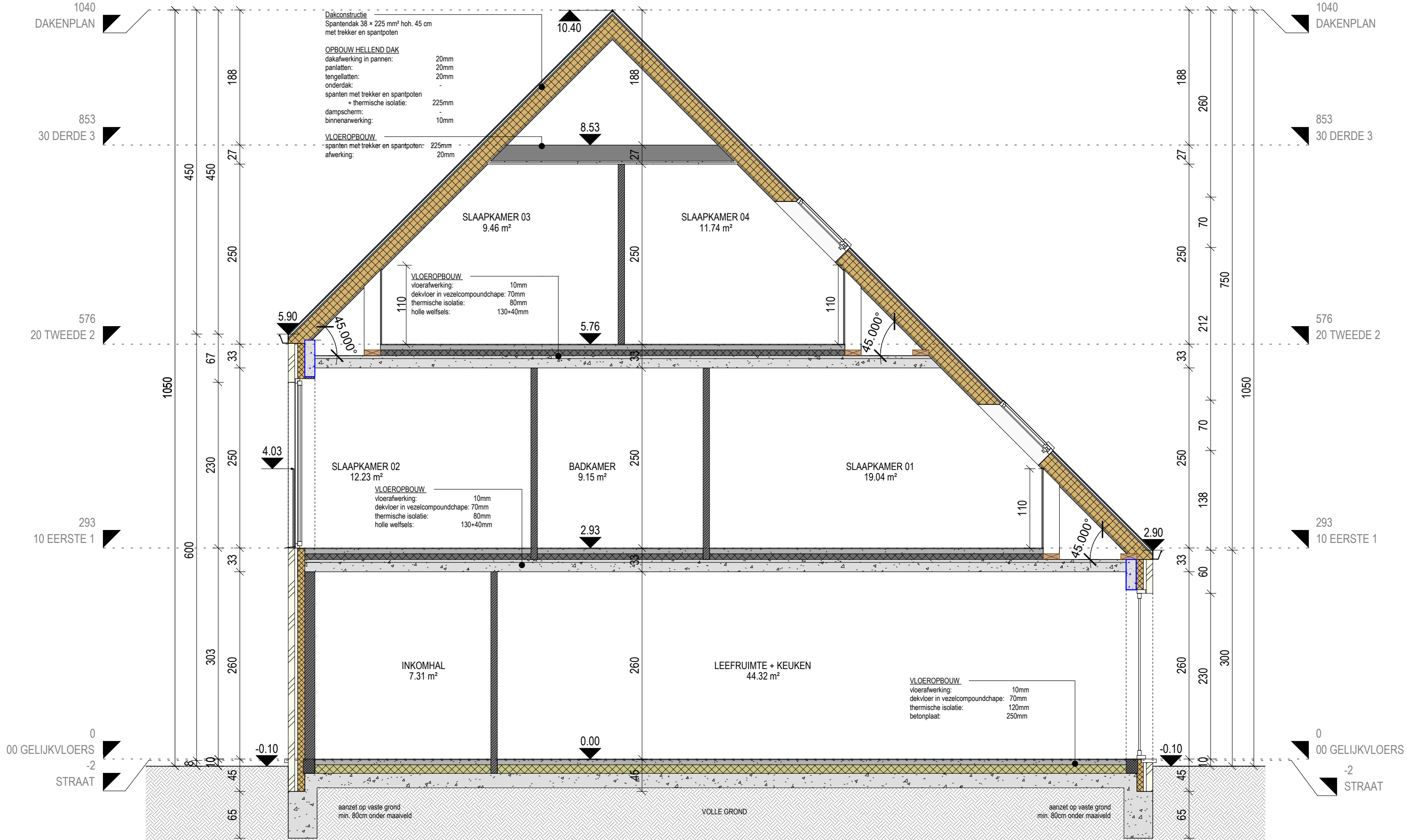

**.danneels**

**ABML**  
ARCHITECTENBUREAU MANU LENDERS

**LOT 1 - 402 m<sup>2</sup>**  
**SNEDE - NIEUWE TOESTAND**

schaal: 1 : 50 - maatvoering in cm  
bouwheer: - D3 Projects  
datum: 02/03/2026

